



TIRE SERVICE INTERNATIONAL

# Model 525 Tire Spinner

[buyTSI.com](http://buyTSI.com) - 800.223.4540



**Read this manual before operating**

Tire Service International, LLC  
3451 S. 40TH ST.  
PHOENIX, AZ 85040

Office: 602.437.5020  
Email: [sales@buytsi.com](mailto:sales@buytsi.com)  
Fax: 602.437.5025

Contact us for any assistance

**800.223.4540**

Revised: March 2024

# Safety Requirements

1. Make sure installation conforms to all applicable Local, State, and Federal Codes, Rules, and Regulations; such as State and Federal OSHA Regulations and Electrical Codes.
2. Carefully check the unit for correct initial function.
3. Read and follow the safety instructions. Keep them readily available for machine operators.
4. Make certain all operators are properly trained, know how to safely and correctly operate the unit, and are properly supervised.
5. Allow unit operation only with all parts in place and operating safely.
6. Carefully inspect the unit on a regular basis and perform all maintenance as required.
7. Service and maintain the unit only with authorized or approved replacement parts.
8. Keep all instructions permanently with the unit and all decals/labels/notices on the unit clean and visible.
9. Do not override safety features.
10. Personal protective equipment helps make tire servicing safer. However, equipment does not take the place of safe operating practices.
  - A. Always wear durable work clothing during tire service activity. Loose fitting clothing should be avoided.
  - B. Tight fitting leather gloves are recommended to protect operator's hands when handling worn tires and wheels.
  - C. Sturdy leather work shoes with steel toes and oil resistant soles should be used by tire service personnel to help prevent injury in typical shop activities.
  - D. Eye protection is essential during tire service activity. Safety glasses with sideshields, goggles, or face shields are acceptable.
  - E. Back belts provide support during lifting activities and are also helpful in providing operator protection.
  - F. Consideration should also be given to the use of hearing protection if tire service activity is performed in an enclosed area, or if noise levels are high.

# Installation Requirements

1. The Model 525 Spinner is a heavy duty, continuous service, overload protected auto and truck spinner. They are powered by a 7 1/2 H.P., 3 phase, 50-60 hertz motor.
2. Branch fuse size should be 60 amps per line or approximately 3 times running amps.
3. Rotation of the spinning bell would be clock-wise looking into the side of the bell. This making tire being spun to rotate downward at the spinner. This makes the brake work properly.

# Operating Instruction Notes

1. Secure the vehicle with appropriate blocks
2. Use a sturdy jack to lift the tire 2 - 3 inches to clear floor
3. Position the unit close to the tire, but not touching
4. Turn on the unit using the toggle switch
5. Push against the wheel until sufficient speed is reached to find the heavy spot
6. The brake is slid over spinning bell and applied to the wheel.
7. Weight is applied to light side of wheel.
8. The action of spin-up and brake is repeated until the tire is balanced.
9. A balanced tire will have no shake and the 501-a will discontinue flashing after balance is within .007 inch tolerance.

# Parts List



Tire Service International, LLC  
3451 S. 40TH ST.  
PHOENIX, AZ 85040  
Office: 602.437.5020  
Email: sales@buytsi.com  
Fax: 602.437.5025

**525 TIRE SPINNER**  
REPAIR PARTS BOM  
October 2021

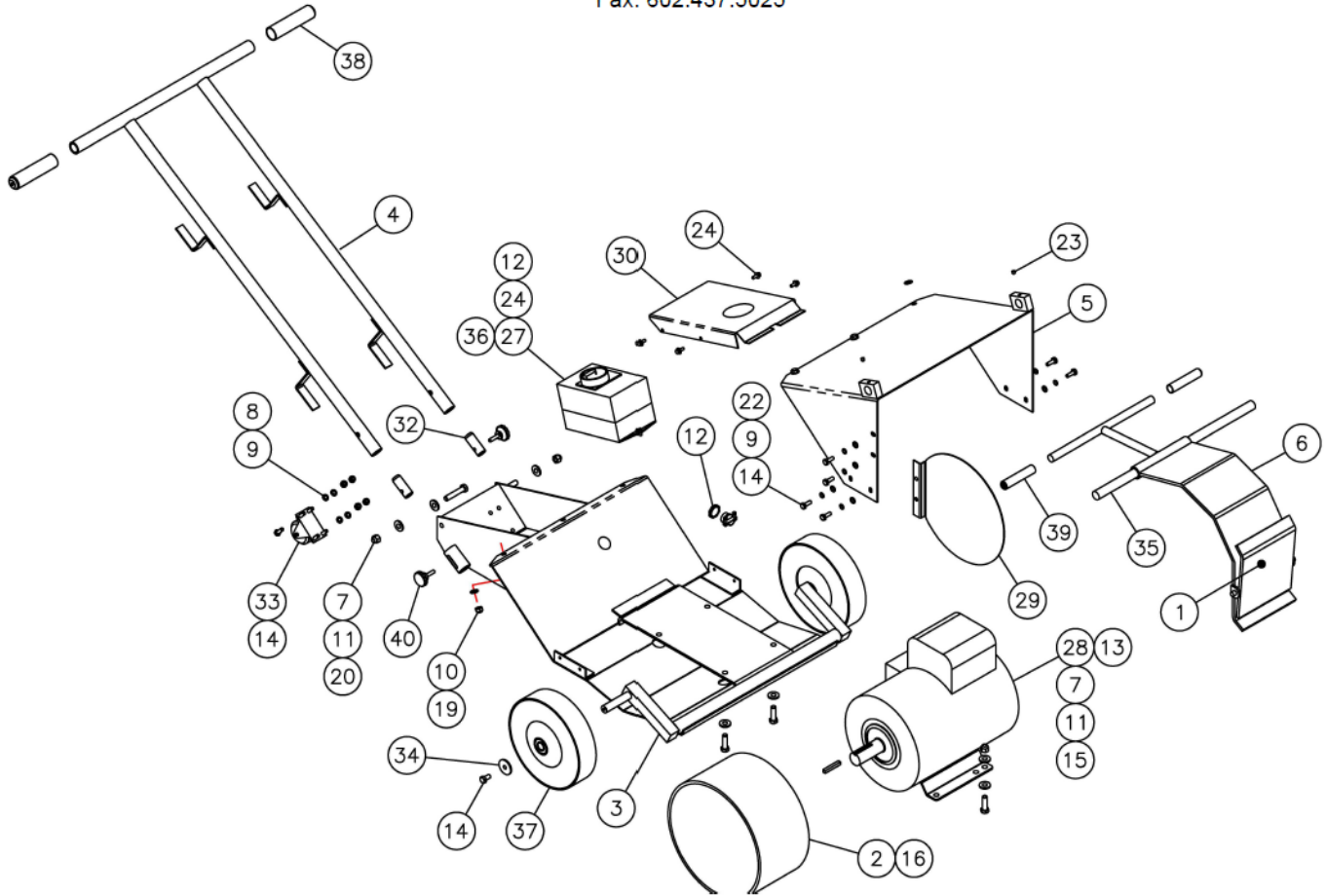

# Parts List



buyTSI.com - 800.223.4540

## 525 TIRE SPINNER

REPAIR PARTS BOM

October 2021

TIRE SERVICE INTERNATIONAL

PARTS LIST			
ITEM	PART NO.	DESCRIPTION	QTY
1	6251	BRAKE WELD	1
2	6255	WHEEL, ROLLER	1
3	6256	BASE, AXLE	1
4	6338	HANDLE, WELD	1
5	6357	FENDER COVER, WELD	1
6	6358	BRAKE, WHEEL STOP	1
7	212 N	NUT 3/8-16 HEX NYLOK	6
8	226-N	NUT 1/4-20 NYLOK	4
9	445	WASHER 1/4 FLAT	6
10	566	NUT 5/16-18 NYLOK	3
11	12758	WASHER 3/8 WROUGHT	10
12	3515	ELEC FLEX CONNECT	4
13	12443	WIRE NUT IDEAL #74 YELLOW	3
14	12468	HHCS 1/4-20 X 3/4 GR2	2
15	447	HHCS 3/8-16 X 1.0	4
16	1308	SHSS 3/8-16 X 5/16 CUP POINT	2
17	1318	WASHER 5/16 WROUGHT	16
18	1354	WASHER 3/8 LOCK	2
19	1819	SELF TAP 1/4-20 X 3/4 WASHER HEAD	4
20	3404	HHCS 3/8-16 X 2	2
21	719	HHCS 3/8-16 X 1-1/2 GR5	2
22	4134	WASHER 1/4 SPRING LOCK PLATED	2
23	275.028	SHSS 1/4-20 X 3/8 CUP POINT PLAIN	2
24	4569	HWHST #10-24 X 3/4 TYPE 23 PLATED	6
25	4782	DECAL - SAFETY GLASSES	1
26	1737	HWHST 5/16 X 3/4	3
27	10678	SWITCH, 1 AND 3 PHASE	3
28	15048	MOTOR 5 HP, 3500 RPM, 208/230V 1PH	REF
	15049	MOTOR 7-1/2 HP, 3500 RPM, 208-460V 3PH	1
29	15080	COVER, ROLLER	1

PARTS LIST			
ITEM	PART NO.	DESCRIPTION	QTY
30	15081	COVER, CONTROLS	1
31	15160	DECAL - AMERMAC/STI LARGE	2
32	15251	SLIDE PIN, HANDLE	2
33	15254	WHEEL, ROLLER CASTER 2" OD	1
34	15329	WASHER, FENDER 3/8 X 1-1/2	2
35	15425	SHAFT, BRAKE BAR	1
36	15463	CORD 10/4 AWG	20'
37	15468	WHEEL, 8"OD X 2-1/2" WIDE	2
38	231	HANDLE, 1" Black	2
39	15470	HANDLE, 5 RED GRIP	2
40	15471	KNOB, HANDLE - PIN	2
41		DECAL - MADE IN USA	1
42			
43			
44			
45			
46			
47			
48			
49			
50			
51			
52			
53			
54			
55			
56			
57			
58			
59			

# Repair Part

Item	Description
15254	WHEEL, ROLLER CASTER 2" OD
15468	WHEEL, 8"OD X 2-1/2" WIDE
10678	SWITCH, SINGLE OR 3-PHASE
15049	MOTOR 7-1/2 HP, 3500 RPM, 208-460V 3PH

buyTSI.com - 800.223.4540



# Notes

# Notes

# California Proposition 65

California's Proposition 65 entitles California consumers to special warnings for products that contain chemicals known to the state of California to cause cancer and birth defects or other reproductive harm if those products expose consumers to such chemicals above certain threshold levels.

**WARNING:** Some of Tire Service International's products can expose you to chemicals including chromium compounds, which are known to the State of California to cause cancer, birth defects or other reproductive harm. For more information, go to [www.P65Warnings.ca.gov](http://www.P65Warnings.ca.gov).

Your risk from exposure to these chemicals varies, depending on exposure time. To reduce your exposure, work in a well-ventilated area and with approved safety equipment, such as dust masks that are specially designed to filter out microscopic particles. Wash your hands after touching TSI's products.

## Warranty and Return Policy

Warranty & Workmanship you can depend on.

With over 30 years of manufacturing experience we maintain the ability to provide competitive prices while employing and manufacturing the majority of our products in the USA. Pride in our workmanship and standing behind each and every product is not just our claim but our uncompromising responsibility.

Tire Service International equipment is warranted to be free from defects in materials and workmanship for a period of one year from the date of original purchase to the original owner. Repair labor is warranted for 90 days from the date of original purchase. Bushings, blades, bearings and normal wear and tear are not covered under warranty. Careless handling, negligence, misuse, abuse, mutilation, improper operation, making unauthorized repairs, additions, and or alterations automatically cancel this warranty and relieves TSI of any obligation. Cheetah tanks claimed to be defective while under warranty will be evaluated at our manufacturing plant and either repaired if possible or exchanged and returned or credit issued to the customer account at our discretion. Damage resulting from dropping the tanks will not receive warranty consideration. Warranty parts need to be returned prepaid to the plant for credit. Any replacement parts shipped from the plant will be shipped at the customer's expense. Machines requiring warranty work must be brought to the manufacturing plant in 201 Chelsea Rd, Monticello, MN or to a repair facility authorized by TSI.

**!!WARNING!!** Goods returned without an RGA will be refused. A Returned Goods Authorization form must be obtained before returning any material or goods. All non-warranty returns will be subject to a 15% restocking fee plus any additional charges for reconditioning/repacking.

Visit [www.buyTSI.com](http://www.buyTSI.com) for any additional information. Also be sure to follow us on all the Socials, and subscribe to our YouTube channel for all our product videos.

No part of this manual may be reproduced without specific approval from  
Tire Service International, LLC.

Copyright © 2024 Tire Service International, LLC

