

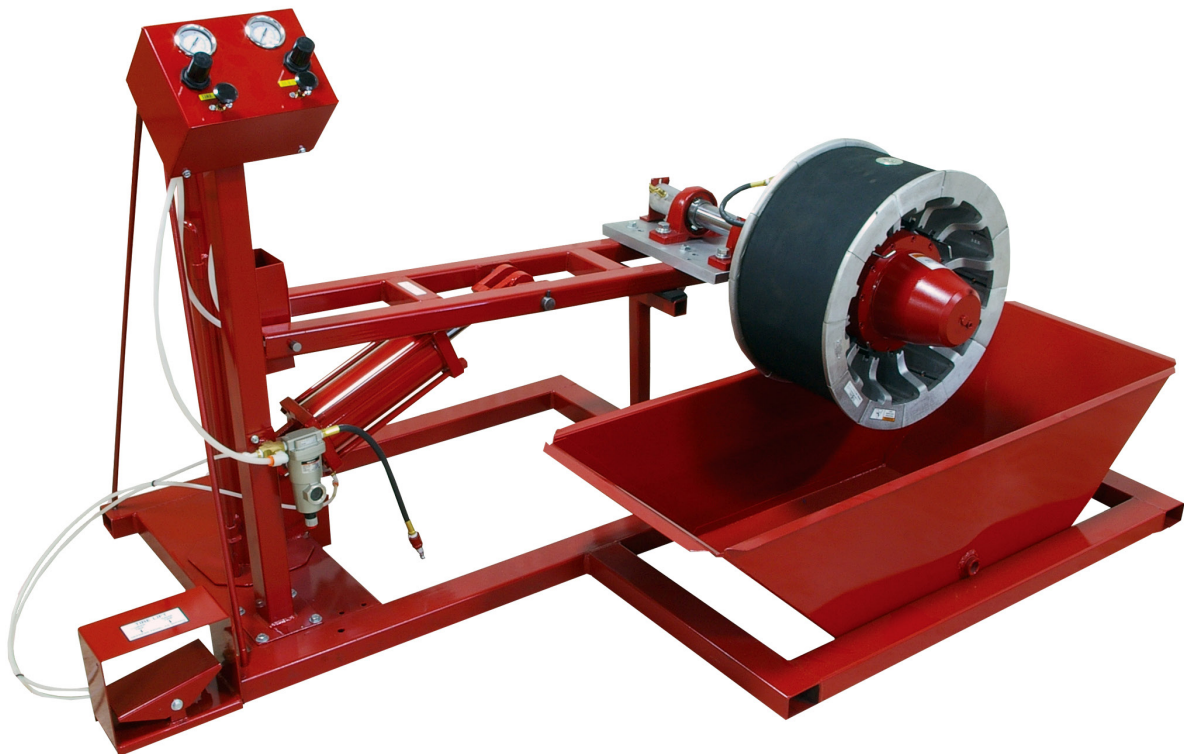

TIRE SERVICE INTERNATIONAL

# TI-96 Tire Inspector with Dunk Tank

[buyTSI.com](http://buyTSI.com) - 800.223.4540



**READ INSTRUCTIONS THOROUGHLY BEFORE OPERATING**

**Tire Service International, LLC**

3451 S. 40TH ST.  
Phoenix, AZ 85040

Office: 602.437.5020  
Email: [sales@buytsi.com](mailto:sales@buytsi.com)  
Fax: 602.437.5025

**Contact us for any assistance**

**800.223.4540**

Revised: March 2024

# General Description

The TI-96 Tire Inspector is designed to inspect non mounted tires from 13" to 24.5" using an expandable hub and rim assembly. The TI-96 allows the operator to inspect tires for tread leakage using a dunk test tank. A foot operated power lift will save time and injury by lifting those heavy tires from floor into the test tank. Quick and easy inspection is accomplished by using an expandable hub and expandable rim assemblies. The TI-96 tire and hub assembly rotates easily for inspection and all operating controls are located on the side of the machine for easy operation.

# Safety Requirements

1. READ THIS MANUAL BEFORE OPERATING
  2. SAFETY GLASSES ARE REQUIRED
  3. Before each use visually inspect the following items:
    - A. Make sure all fittings, hoses, valves and filters are property fastened and secured before operating unit.
    - B. Floor area around unit is dry
- CAUTION: Operation of this machine for use other than checking tires for air leaks is strictly prohibited.

# Installation Requirements

- Suggested incoming air supply to is 125 PSI
- Fasten unit to a flat concrete slab or surface with anchor bolts near a water source and drain. Unit can tip if not secured.

# Set-Up Instructions

- Prepare a clean, level surface with adequate room to maneuver.
- Remove machine from packaging materials.
- Connect air supply to 1/4" hose fitting. All pressures are pre-set for 30 PSI for tire pressure and 80 PSI for expanding hub and rim.
- Select the correct size expansion RIM and mount onto expansion HUB
- Add water to the dunk tank. Leave enough space for the tire. Tip: one gallon of windshield solution added to the tank will help identify leaks.

# Primary Parts

Fig. 1

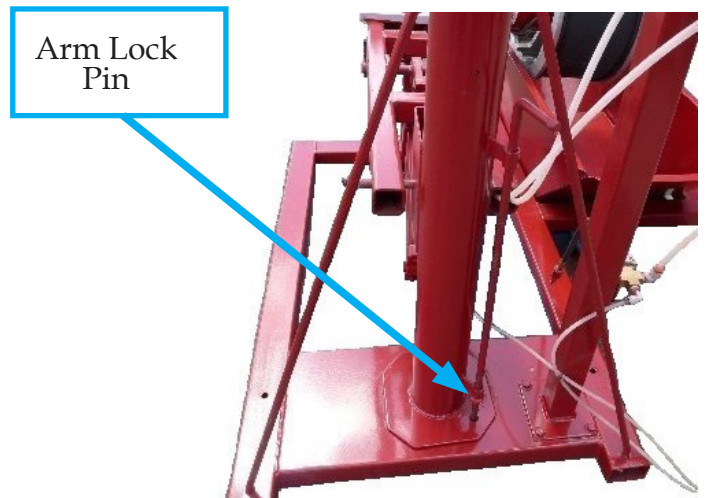
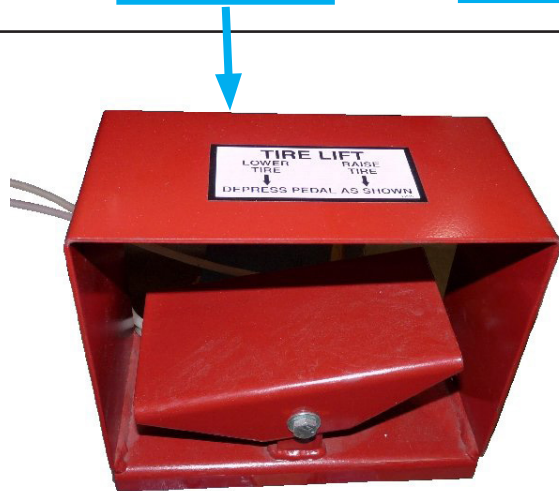
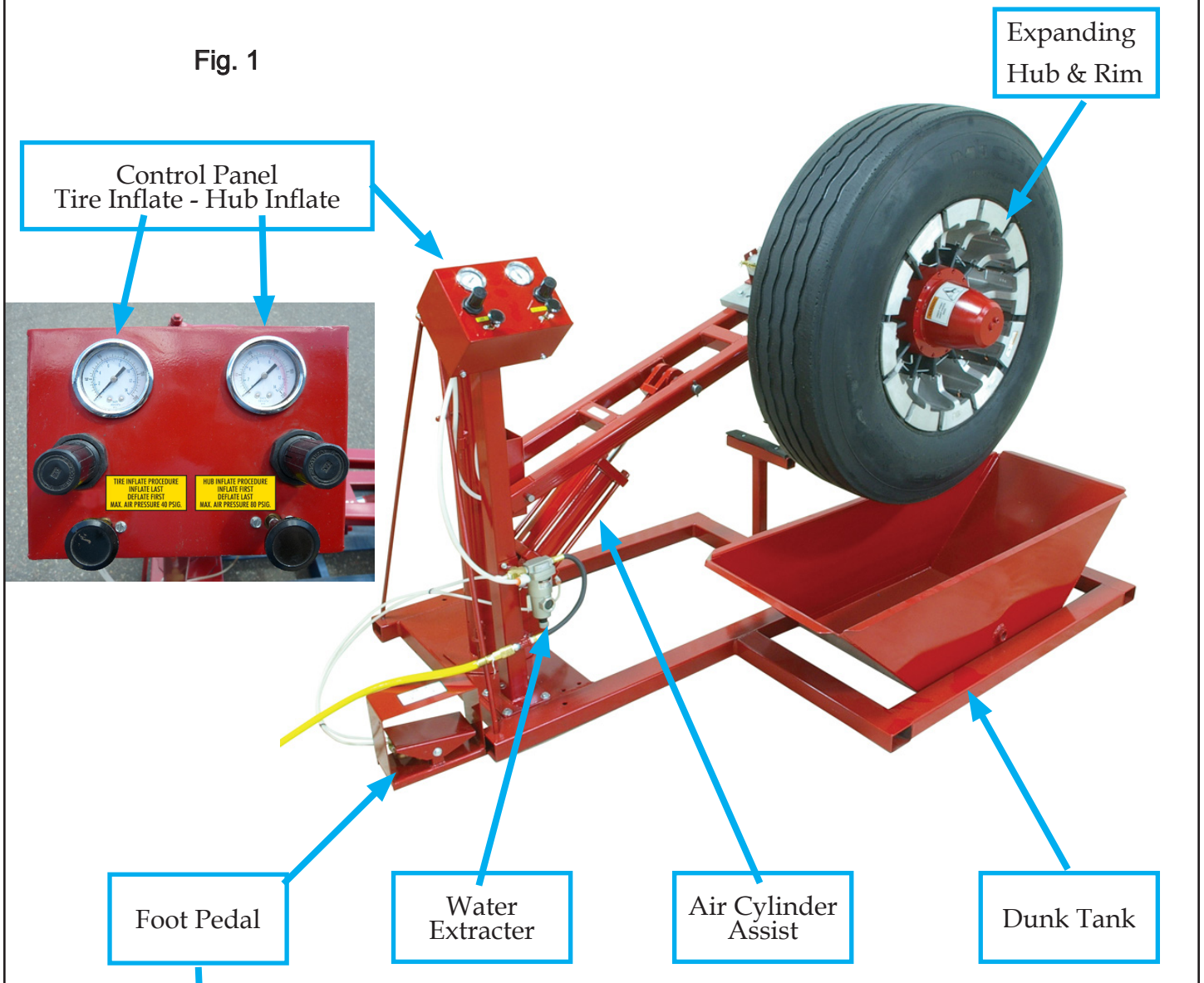

# Operating Instructions

- CAUTION: Operation of this machine for use other than checking tires for air leaks is strictly prohibited.
- Use the foot pedal to raise the Rotating Lift Arm.
- Disengage the Arm Locking Pin and rotate the Lift Arm and Expandable Hub assembly clockwise from the Pivot Post into a clear workspace. Engage the Locking Pin (the arm rotates 45 degrees).
- Clean tire bead and flanges. Use an oil soap on Expanding Rim belt to assist tire to slide into position.
- Lower the Lift Arm to a manageable height and mount the tire.
- Raise the Lift Arm slightly to get the tire off the ground.
- Pull the knob to the expand the rim.
- After the rim has fully expanded, inflate the tire by pulling the tire knob. Some air loss may occur between the expanded rim and tire.
- Raise the Lift Arm high enough to clear the dunking tank edge using the foot pedal.
- Disengage the Arm Locking Pin and rotate the tire over the dunk tank and engage the pin.
- Lower the tire into the water to within 1½" of the tire bead. Tire MUST NOT touch the bottom of the tank during this process.
- Slowly spin the tire on the Hub and check for air bubbles.
- Follow reverse process for removal - raise, unlock pin, rotate, lock pin, lower
- Push TIRE knob to deflate tire. After the tire is deflated, push the HUB knob to collapse the expansion rim. Warning: Deflate tire fully before deflating the hub. Do not remove tire until hub is fully deflated.
- Remove tire.
- Remove any debris from expansion rim and flanges. Clean the expansion rim.
- If excess water gets inside Hub disassemble the enter hub, clean and dry all parts. Use marine grease and assemble.



## WARNING

**Be careful when inflating tires! TSISSG assumes no responsibility and is not liable if tires explode or come off of this rim assembly because of excessive air pressure.**

# Maintenance

1. Daily, inspect assembly for loose fittings, damaged parts, or water in the expanded rim assembly.
2. Weekly or as needed, empty, clean, and refill water in tank.
3. Every 30 days, grease all zerks with standard Chassis grease.

## Expanding Rims

### AVAILABLE SIZES



**9.410**  
14" - 17" x 7 1/8"



**10.410**  
17" - 20" x 8 1/4"

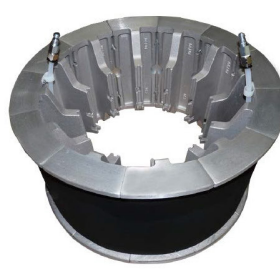

**11.410**  
20" - 22.5" x 9"



**12.410**  
22" - 24.5" x 9"

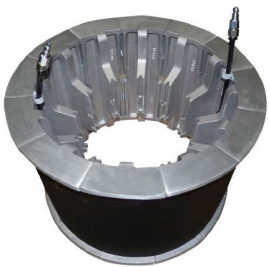

**13.410**  
20" - 22.5" x 11 3/4"



**14.710**  
14" - 17" x 10"



**172010**  
17" - 20" x 10"

# Parts Listing

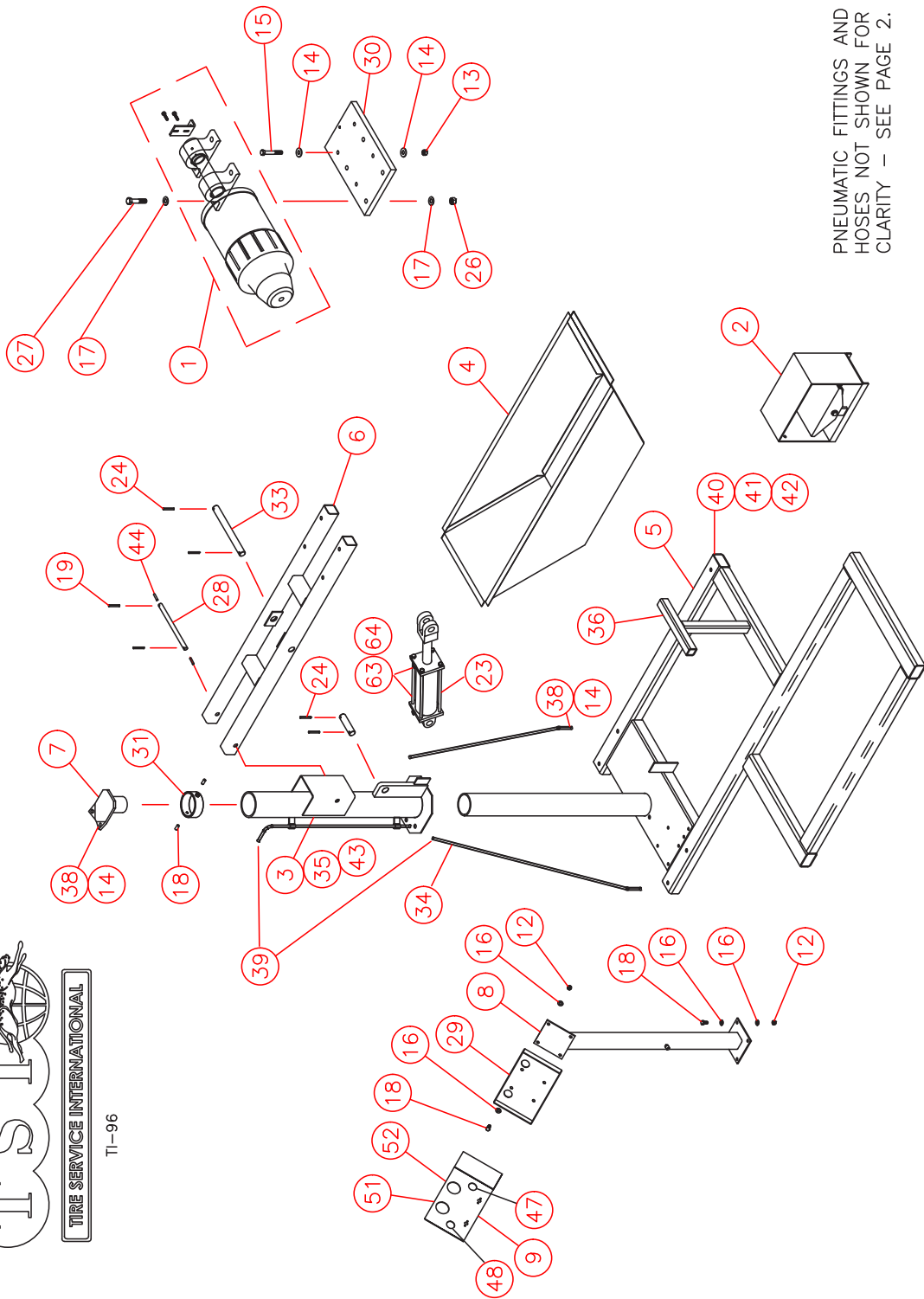

PNEUMATIC FITTINGS AND HOSES NOT SHOWN FOR CLARITY - SEE PAGE 2.

THE SUBJECT OF THIS DRAWING IS SUBMITTED IN CONFIDENCE AND IT AND THE DRAWING WILL BE KEPT AS SUCH BY TIRE SERVICE INTERNATIONAL, INC. AND ARE NOT TO BE USED WITHOUT ITS WRITTEN PERMISSION AND APPROVAL. © 2021	MAT'L:	DESIGNER:	SCALE: NA	REV	DESCRIPTION	DATE
TOLEANCE UNLESS NOTED: DIMENSIONS ±.010 FRACTIONS ±1/32 ANGLES ±12°		DR. BY: CH. BY:	DATE: 1-18-21	USED ON: TI-96	TIRE DUNKER (TRUCK MODEL)	1 OF 1
			INT:	PHOENIX, AZ MONTICELLO, MN		
				TIRE SERVICE INTERNATIONAL, LLC		
				DWG NO. A	TI-96 MAIN	CITY UNIT: 1

1. REMOVE ALL BURRS & SHARP EDGES.  
NOTE:

# Parts Listing

TI-96 Parts		Tire Inspector/Dunker Truck Includes PN 12.410 22-24.5 Expanding Rim					
ID	Component	Description	Qty	ID	Component	Description	Qty
01	5840	# Expandable Hub	1	39	230	# Handle Grip	3
02	5994	# Foot Pedal Valve Assembly	1	40	213	# Bolt, Carriage 1/4-20 x 3-1/2 Plated	2
03	6224	# Tube Swivel Weld	1	41	226-N	# Nut 1/4-20 Nyloc	2
04	6225	# Tank Weld	1	42	12758	# Washer 1/4 Flat SAE	2
05	6226	# Frame Weld Assy	1	43	3501	# Zerk Grease Fitting 1/8 NPT Straight	2
06	6227	# Lift Arm Weldment	1	44	12856	# Lift Arm Spacer	2
07	6229	# Ear Plate Weld	1				
08	6230	# Control Panel Mount Weld	1				
09	6231	# Control Box Weld	1				
12	212-N	# Nut 3/8-16 Nyloc	8				
13	223	# Nut 1/2-13 Nyloc	4				
14	224W	# Washer 1/2 x 1.33 Wrought	8				
15	366-GR8	# HHCS 1/2-13 x 4 Grade 8	4				
16	1318	# Washer 5/16	16				
17	987	# Washer 5/8 Wrought Flat Plated	8				
18	1306	# HHCS 3/8-16 x 1	10				
19	12452	# Pin, Spring 1/8 x 1 1/8 Plain	2				
23	12741	# Cylinder 5 x 8 x 1 1/2	1				
24	3470	# Pin, Spring 3/16 x 2 st	4				
26	4836-2 WAY	# Nut 5/8-11 Centerlock	4				
27	10402	# HHCS 5/8-11 x 3 Grade 5	4				
28	12391	# Pin, Lift Pivot	1				
29	12398	# Plate, Control Box	1				
30	12399	# Plate, Hub Mount	1				
31	12402	# Collar, Lock Weld 3-1/2 DIA	1				
33	12407	# Pin, Cylinder Top	1				
34	12418	# Brace, Pedestal Rod	2				
35	12420	# Rod, Swing Lock	1				
36	12912	# Pad, Rubber .5 x 1.5 x 12.5	1				
38	26.055	# Nut 1/2-13 Jam	8				

# Pneumatic Part Listing

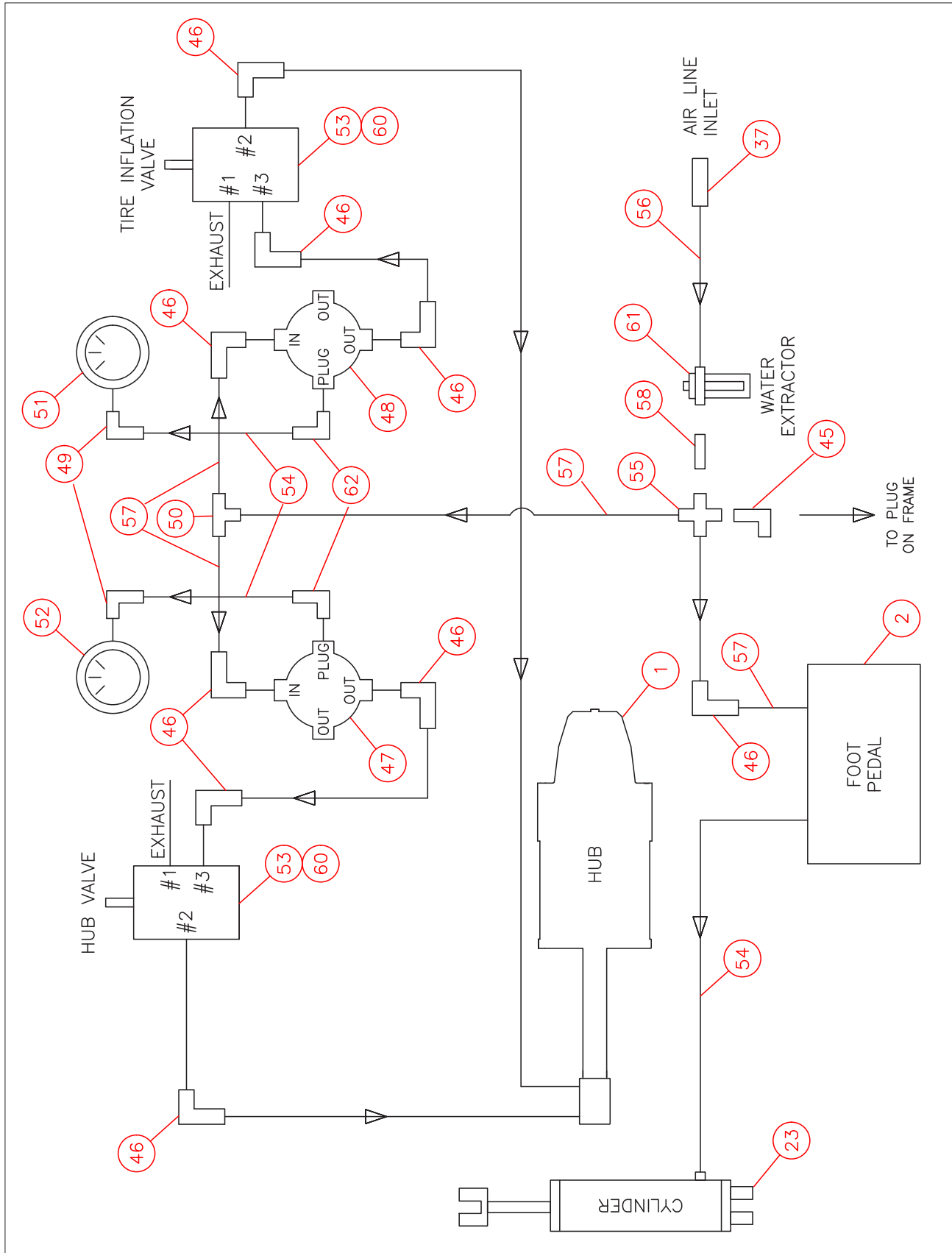



# Pneumatic Parts Listing

## TI-96 HYDRAULICS Tire Inspector/Dunker Truck Includes PN 12.410 22-24.5 Expanding Rim

ID	Component	Description	Qty	ID	Component	Description	Qty
37	730	# Coupling 1/4 NPT	1				
45	342.096	# Elbow 1/4 NPT M x 1/4 Push-Loc	1				
46	10215	# Nipple 1/4 NPT x 3/8 Push-lok	9				
47	15.190	# Regulator, Air 125 PSI	1				
48	12640-40	# Regulator, Air 40 PSI	1				
49	11765	# Elbow 1/4 x 1/4-18 F x 90	2				
50	11884	# Tee 3/8 Nylon Push-loc	1				
51	11554-60	# Gauge, 2" x 60 PSI x 1/4 NPT	1				
52	11554-160	# Gauge, 2" x 160 PSI x 1/4 NPT	1				
53	252.190	# Valve Mini Push Pull	2				
54	460.268	# 1/4 OD x .17 ID Tubing	10				
55	911	# Tee 1/4 NPT pipe cross	1				
56	4931	# Hose 1/4 x 14" OAL 300 PSI x 1/4 NPT Male	1				
57	10080	# Tubing .375 O.D.x .25 ID	3				
58	778	# Nipple 1/4 Black	2				
59	4862	# HWHST 1/4-14 x 1 Self Drilling	4				
60	265.028	# HWSLTCS #8-32 X 3/8 23	4				
61	10676	# Water Extractor	1				
62	379.096	# Elbow 1/8 NPT M x 90 tubing push in	2				
63	1323	# Reducer, Bushing 1/2 x 1/4	2				
64	1767	# Air Muffler 1/4	1				
65	214	# Nut 1/4-20	2				

# Notes

# Notes

# California Proposition 65

California's Proposition 65 entitles California consumers to special warnings for products that contain chemicals known to the state of California to cause cancer and birth defects or other reproductive harm if those products expose consumers to such chemicals above certain threshold levels.

**WARNING:** Some of Tire Service International's products can expose you to chemicals including chromium compounds, which are known to the State of California to cause cancer, birth defects or other reproductive harm. For more information, go to [www.P65Warnings.ca.gov](http://www.P65Warnings.ca.gov).

Your risk from exposure to these chemicals varies, depending on exposure time. To reduce your exposure, work in a well-ventilated area and with approved safety equipment, such as dust masks that are specially designed to filter out microscopic particles. Wash your hands after touching TSI's products.

## Warranty and Return Policy

Warranty & Workmanship you can depend on.

With over 30 years of manufacturing experience we maintain the ability to provide competitive prices while employing and manufacturing the majority of our products in the USA. Pride in our workmanship and standing behind each and every product is not just our claim but our uncompromising responsibility.

Tire Service International equipment is warranted to be free from defects in materials and workmanship for a period of one year from the date of original purchase to the original owner. Repair labor is warranted for 90 days from the date of original purchase. Bushings, blades, bearings and normal wear and tear are not covered under warranty. Careless handling, negligence, misuse, abuse, mutilation, improper operation, making unauthorized repairs, additions, and or alterations automatically cancel this warranty and relieves TSI of any obligation. Cheetah tanks claimed to be defective while under warranty will be evaluated at our manufacturing plant and either repaired if possible or exchanged and returned or credit issued to the customer account at our discretion. Damage resulting from dropping the tanks will not receive warranty consideration. Warranty parts need to be returned prepaid to the plant for credit. Any replacement parts shipped from the plant will be shipped at the customer's expense. Machines requiring warranty work must be brought to the manufacturing plant in 201 Chelsea Rd, Monticello, MN or to a repair facility authorized by TSI.

**!!WARNING!!** Goods returned without an RGA will be refused. A Returned Goods Authorization form must be obtained before returning any material or goods. All non-warranty returns will be subject to a 15% restocking fee plus any additional charges for reconditioning/repacking.

Visit [www.buyTSI.com](http://www.buyTSI.com) for any additional information. Also be sure to follow us on all the Socials, and subscribe to our YouTube channel for all our product videos.

No part of this manual may be reproduced without specific approval from  
Tire Service International, LLC.

Copyright © 2024 Tire Service International, LLC

